

宽型平行气爪 HP08系列



HP08系列

宽型平行气爪

- ◆ **超轻量、薄型**
- ◆ **长行程**
开闭行程长、轻量紧凑。
- ◆ **贯通安装孔**
本体采用贯通安装孔，提高了安装性能。
- ◆ **高夹持力、高刚性**
采用双活塞方式，实现了高夹持力。
- ◆ **埋入式开关**
采用ZE型、ES型开关

宽型平行气爪

HP08系列

型号表示记号

HP08 - 12 ※ ZE235 A 2

系列名

缸径

12: 12mm
16: 16mm
20: 20mm
25: 25mm

开关数量

1: 带1个
2: 带2个

开关引线长度

A: 1m
B: 3m



●开关详细规格→P.521~528

HP08系列

宽型平行气爪

内部结构图

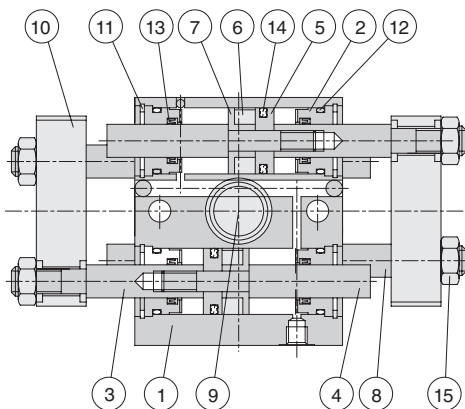

零件表

序号	名称	材质
1	本体	铝合金
2	活塞杆盖	铝合金
3	活塞杆A	不锈钢
4	活塞杆B	不锈钢
5	活塞	铝合金
6	磁铁	树脂
7	磁铁压块	铝合金
8	导杆	不锈钢
9	齿轮	不锈钢
10	夹指	铝合金
11	孔用扣环	碳钢
12	O形环	NBR
13	活塞杆密封件	NBR
14	活塞密封件	NBR
15	六角螺母	碳钢



规格

使用流体	空气
最大使用压力 [MPa]	0.7
使用压力范围 [MPa]	0.2~0.7
耐压 [MPa]	1.05
使用环境温度范围 [°C]	0~60 (无冻结)
注油	不需要 (机械滑动部需要)
配管口径	M5×0.8
最大使用频率 [Cycle/min]	120
重复精度 [mm]	±0.07
适用开关	ZE·ES型 (无触点开关)

动作方式	型号	缸径 [mm]	开闭行程 [mm]	夹指螺钉 (4处)	夹持力 [N]		外形尺寸 (高×宽×长) [mm]	产品质量 [g]
					闭合时	开启时		
双作用型	HP08-12	φ 12×2	24	M4×0.7	27	27	50×44×27	230
	HP08-16	φ 16×2	32	M5×0.8	55	55	80×50×32	400
	HP08-20	φ 20×2	40	M6×1	85	85	70×60×40	760
	HP08-25	φ 25×2	50	M8×1.25	135	135	84×66×44	1100

注) 夹持力在开闭行程的中间位置测定。为夹持点L=30mm、压力0.5MPa时的有效值。

气爪安装示例

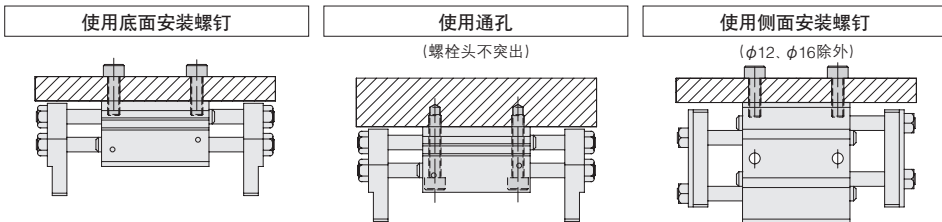

开关迟滞

迟滞是指从夹指移动后开关接通的位置开始，反向移动到开关切断时的距离。

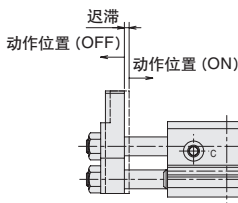

型号	迟滞 [mm]	动作位置精度 [mm]	
		迟滞	动作位置精度
HP08-12	0.3	0.2	0.2
HP08-16	0.3	0.2	0.2
HP08-20	0.3	0.2	0.2
HP08-25	0.3	0.2	0.2

开关安装

将开关插入开关安装槽。设定安装位置后，用钟表螺丝刀拧紧开关固定用螺钉。紧固扭矩为0.1N·m以下。

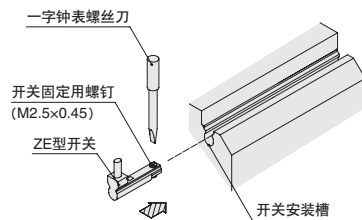

开关突出量

HP08系列的开关无突出。

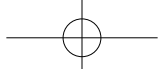

宽型平行气爪

HP08系列

有效夹持力

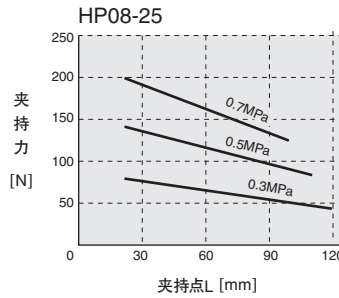
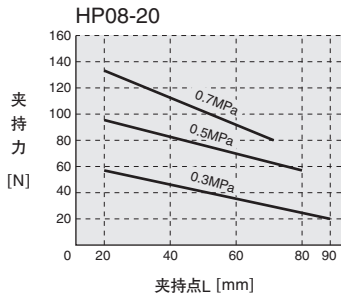
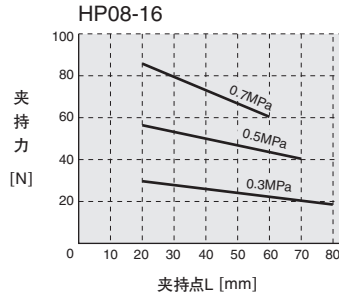
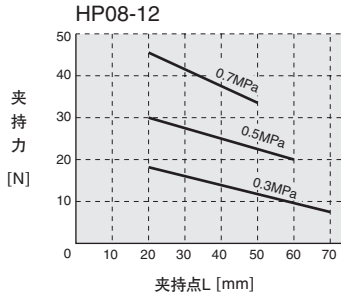

HP08系列

宽型平行气爪

夹持点限制范围

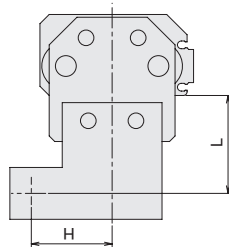
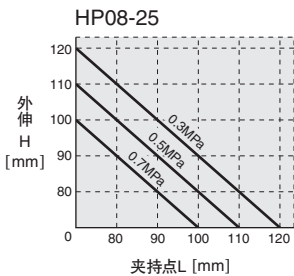
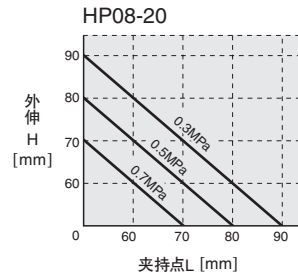
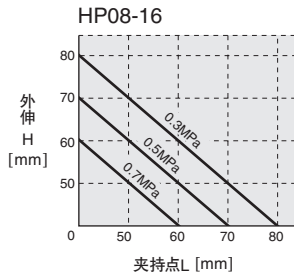
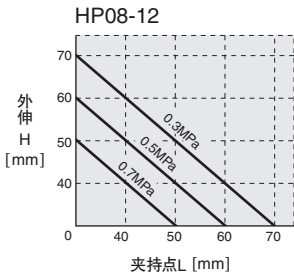



■外形尺寸图 HP08-12

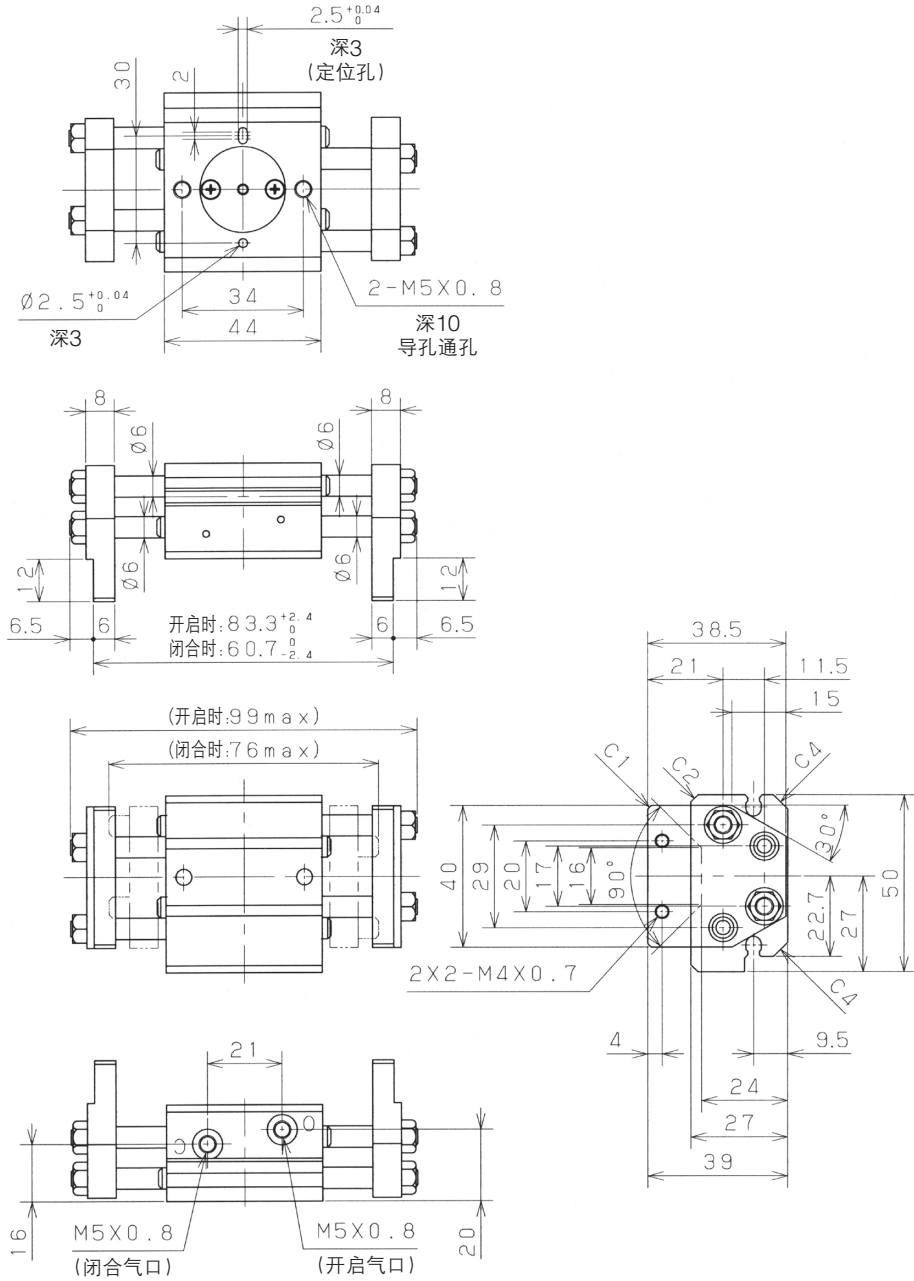

HP08系列

宽型平行气爪



宽型平行气爪

HP08系列

备有CAD数据

外形尺寸图 HP08-16

HP08系列

宽型平行气爪

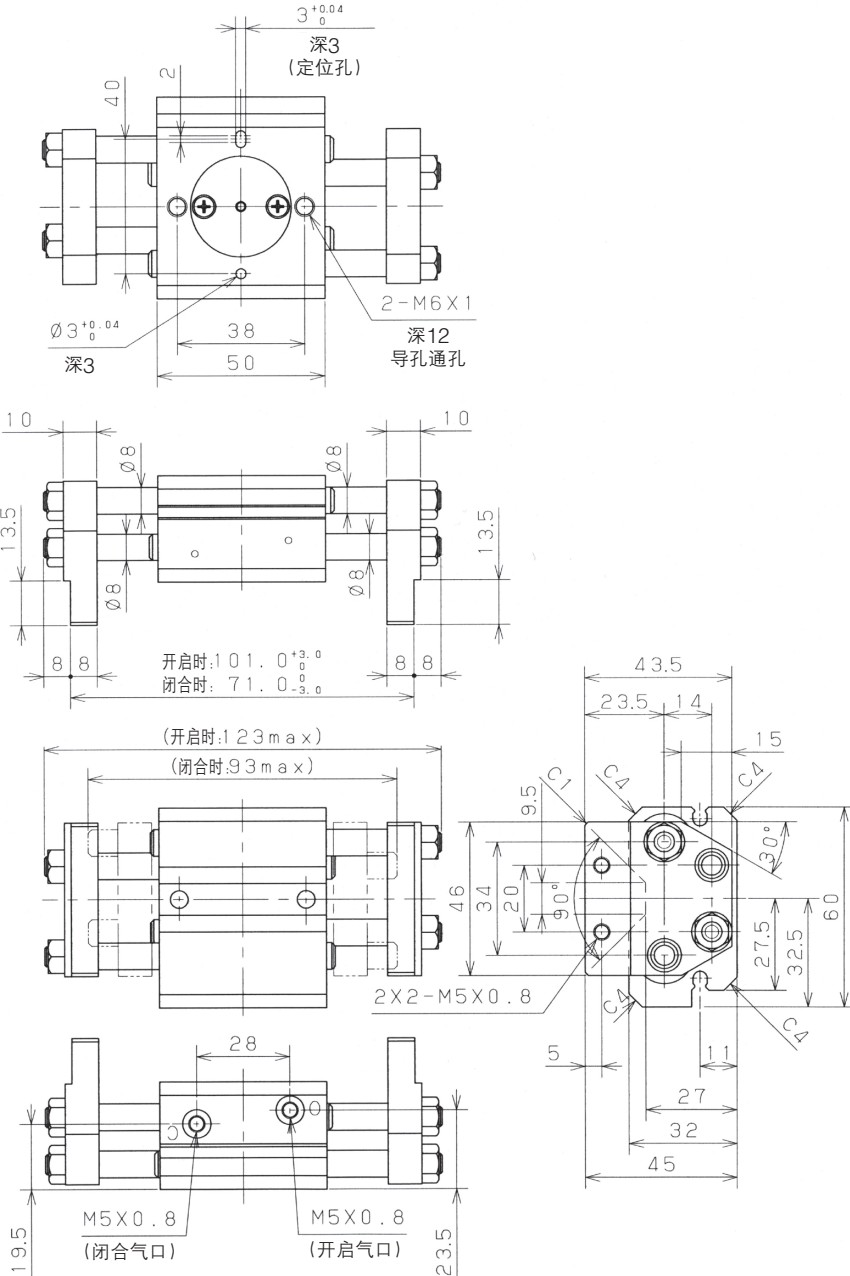

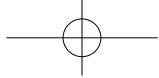

外形尺寸图 HP08-20

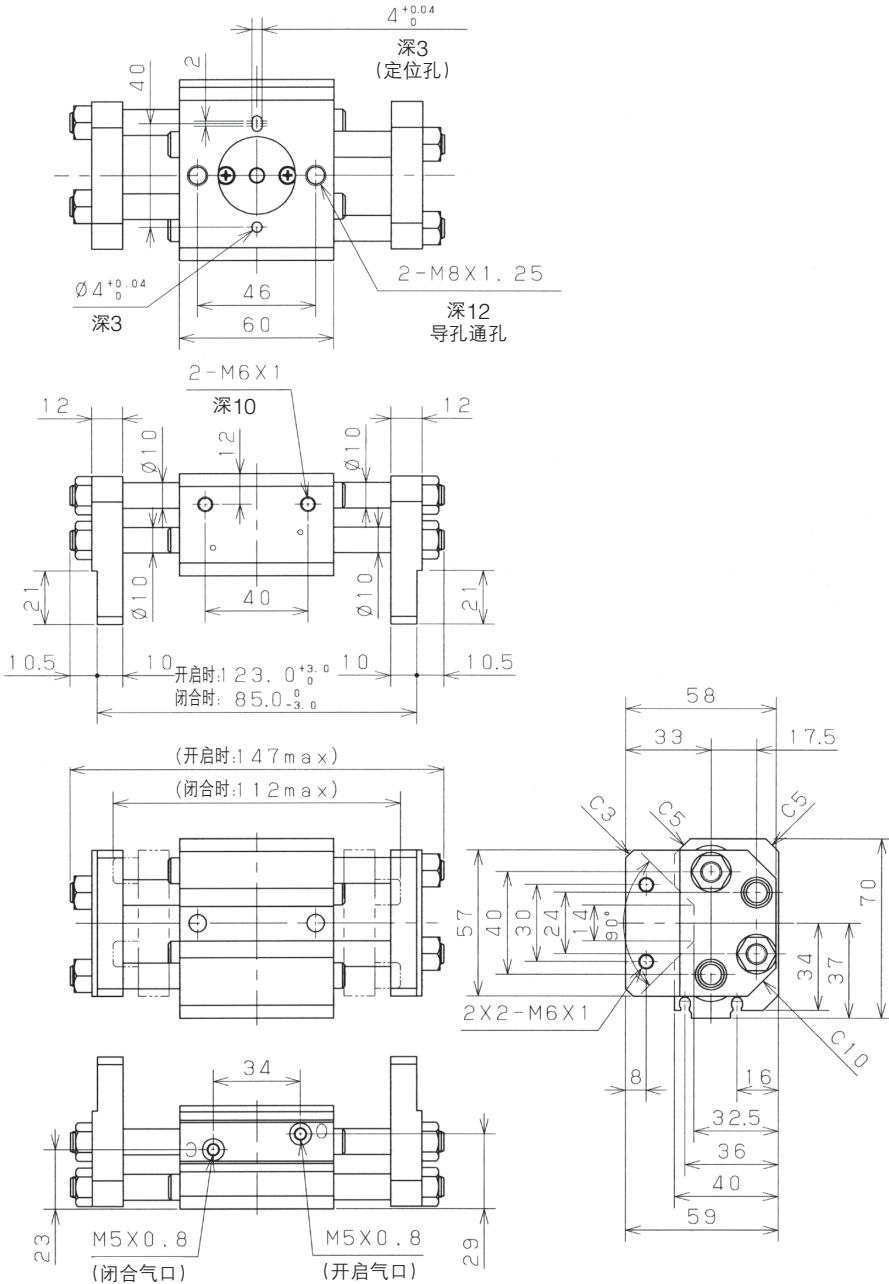

HP08系列

宽型平行气爪



宽型平行气爪

HP08系列

备有CAD数据

外形尺寸图 HP08-25

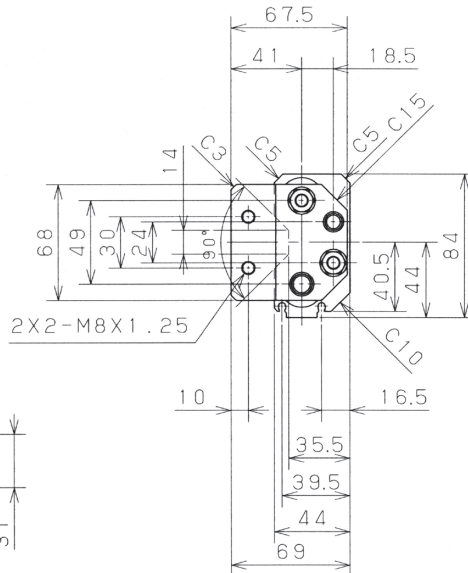
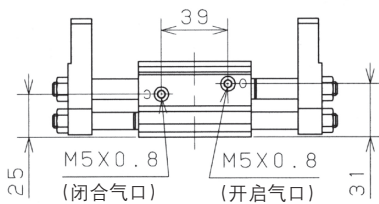
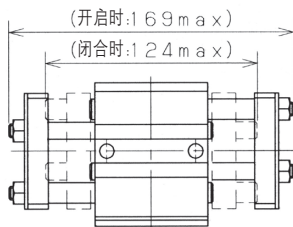
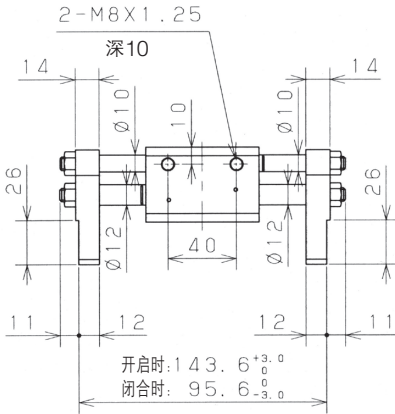
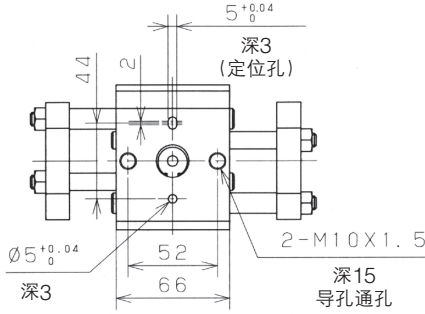

HP08系列

宽型平行气爪